



PRODUCT:

DC050 DOOR CAP FOR USE WITH FLUSH BOLT OR CONCEALED VERTICAL ROD ORDER TEMPLATE

COMPANY INFORMATION

COMPANY NAME: CONTACT NAME:
 ADDRESS: EMAIL ADDRESS:
 CITY: STATE/PROVINCE: POSTAL CODE:
 PHONE: FAX: DISTRIBUTOR:



DC050.630
ISO VIEW OF
INACTIVE DOOR SIDE

ADDITIONAL INFORMATION

QUANTITY: FINISH: CAP HEIGHT:
 MOUNTING: DOOR WIDTH: DOOR BEVEL: DOOR THICKNESS:
 HANDING: FB OR CVR MANUFACTURER:
 CUSTOMER NOTES:



DC050.630
ISO VIEW OF
ACTIVE DOOR SIDE

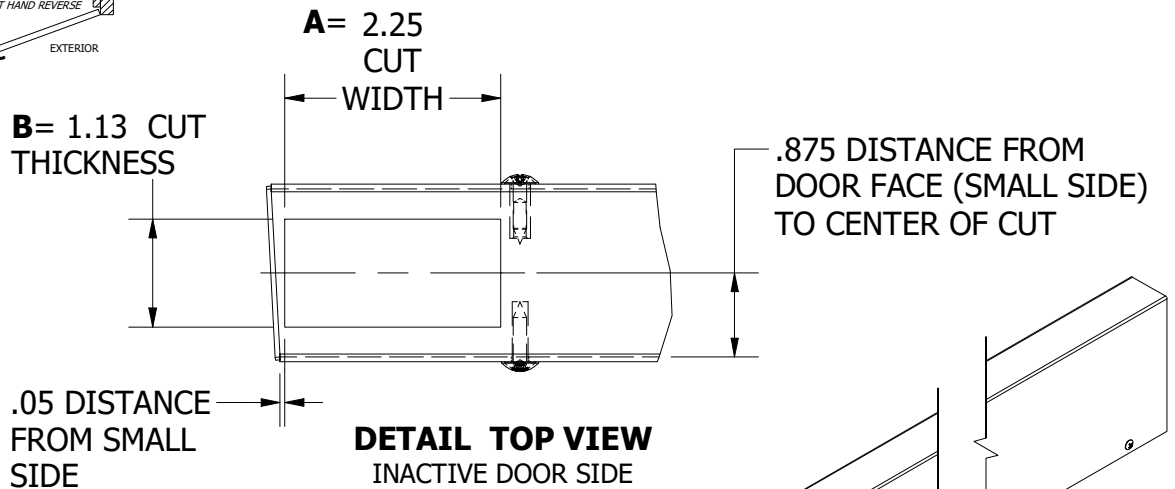
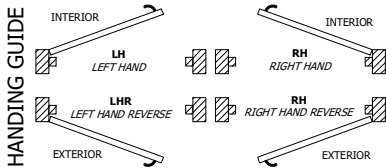

NOTES:

- DIMENSIONS ARE IN INCHES
- NUMBER OF SCREW HOLES VARY DEPENDING ON DOOR WIDTH
- DO NOT PREDRILL DOOR
- PRODUCT SHOWN IS FOR REFERENCE ONLY
- PRODUCT COMES WITH #6 X 5/8 TRUSS HEAD SHEET METAL SCREWS FOR SURFACE MOUNTING
- PRODUCT COMES WITH #8 TRUSS HEAD MACHINE SCREWS AND SEX BOLTS FOR THRU-BOLT MOUNTING
- HORIZONTAL GRAIN DIRECTION FOR SATIN FINISHES
- TRIMCO ADDS 1/16" TO DIMENSIONS **A** AND **B** FOR TOLERANCE REQUIREMENTS
- PLACE ORDER WITH CUSTOMER SERVICE
- EMAIL: CSR@TRIMCOHARDWARE | PHONE: (323) 262-4191

FOR TRIMCO USE ONLY

FOR TOP LEVEL ASSEMBLY, BOM, AND OTHER ENGINEERING DOCUMENTATION, SEE DWG# **19817** FOR INACTIVE VERSION **19819** FOR ACTIVE VERSION

PART#:

TEMPLATE# 22422

SHEET

1 OF 1

REVISION# 1

This template is provided for use only on the job for which it was requested. Trimco reserves the right to make design changes without notice. Trimco will not be responsible for errors or damage caused by the use of out-of-date templates.

TRIANGLE BRASS MANUFACTURING
1351 ROCKY POINT DRIVE
OCEANSIDE, CA 92056
WWW.TRIMCOHARDWARE.COM

APPROVED ON: 5/3/2023