



Trimco
SINCE 1949

PRODUCT:

1010 PULL PLATE TEMPLATE

NOTES:

- DIMENSIONS IN INCHES UNLESS SPECIFIED.
- PRODUCT FOR 1.75" THICK DOOR UNLESS SPECIFIED BY CUSTOMER.
- PLATE THICKNESS CHANGES TO .048 FOR HEALTHY HARDWARE FINISHES.
- DO NOT PRE-DRILL DOOR DUE TO VARIATIONS IN SCREW HOLE LOCATIONS.
- ROUNDED CORNERS AVAILABLE ON REQUEST.
- AVAILABLE IN MANY FINISH TYPES. SEE CATALOG FOR AVAILABILITY.

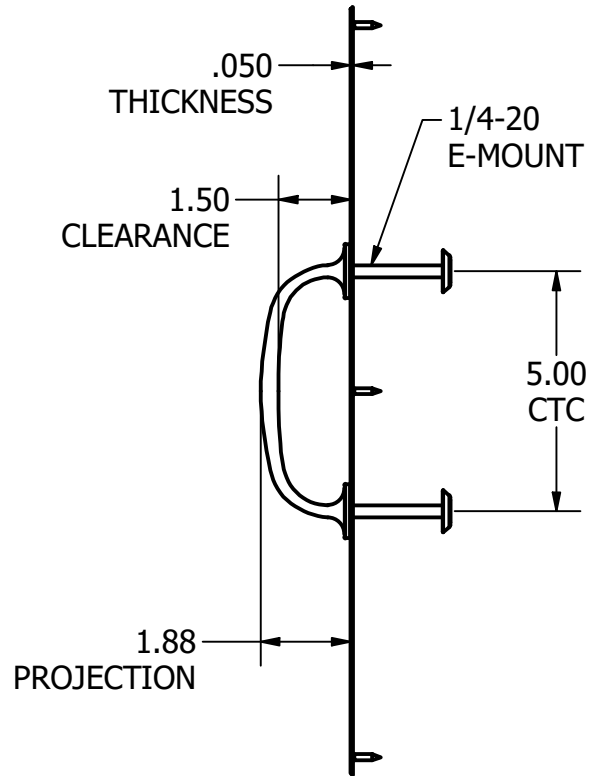
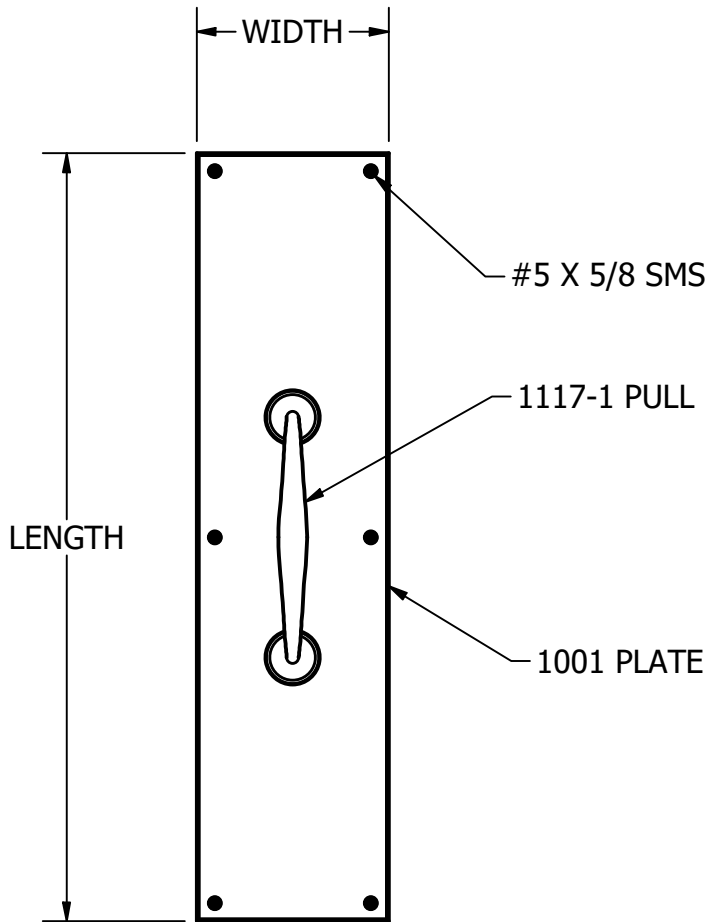

TABLE

PART NUMBER FAMILY	LENGTH	WIDTH
1010-1	12	3
1010-2	15	3.5
1010-3	16	4

TEMPLATE# 21985

SHEET

1 OF 1

REVISION# 2

APPROVED ON: 4/12/2023

This template is provided for use only on the job for which it was requested. Trimco reserves the right to make design changes without notice. Trimco will not be responsible for errors or damage caused by the use of out-of-date templates.

TRIANGLE BRASS MANUFACTURING
1351 ROCKY POINT DRIVE
OCEANSIDE, CA 92056
WWW.TRIMCOHARDWARE.COM