

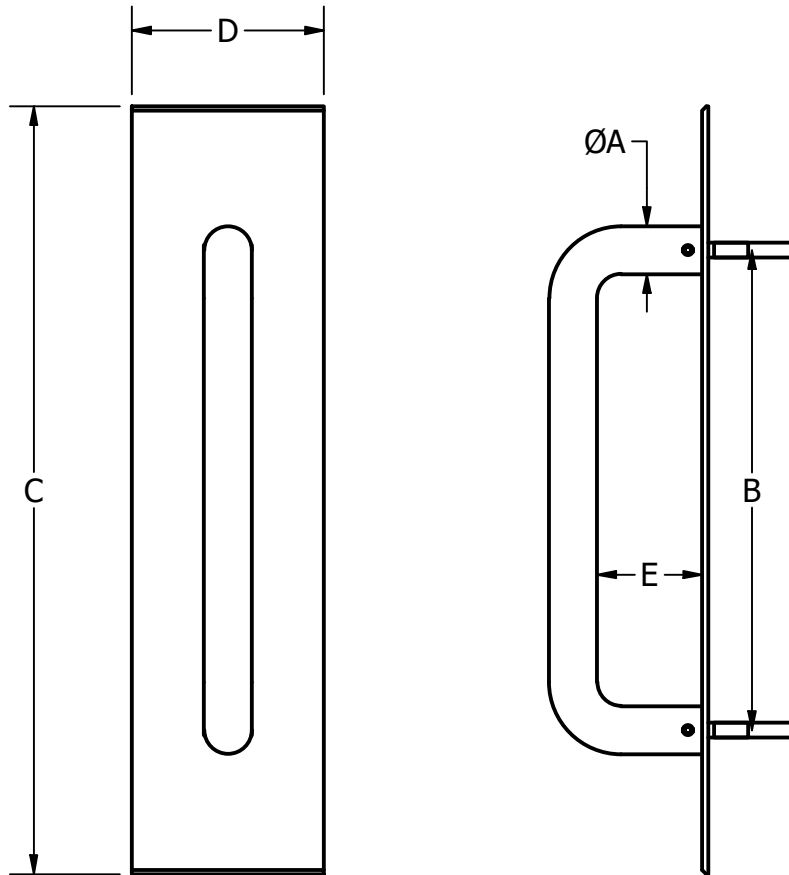

DOOR PREP:

1. DRILL $\varnothing 3/8$ " HOLES, (HANDLE CENTER) DISTANCE APART.
2. INSTALL PUSH PLATE THROUGH HOLES.
3. HOLD PULL PLATE OVER HOLES AND INSERT MOUNTING POSTS THROUGH PULL PLATE THEN DOOR.
4. THREAD SHOULDER BOLTS INTO PUSH PLATE.
5. MOUNT HANDLE ON POSTS USING FOUR (4) SUPPLIED SET SCREWS.



PART#	DIM A	DIM B	DIM C	DIM D	DIM E
1894-3	0.75	6.0	15.0	3.5	1.88
1894-3B	0.75	8.0	15.0	3.5	1.88
1894-4	0.75	6.0	16.0	4.0	1.88
1894-4B	0.75	8.0	16.0	4.0	1.88
1895-3	1.00	8.0	15.0	3.5	2.19
1895-3B	1.00	10.0	15.0	3.5	2.19
1895-4	1.00	8.0	16.0	4.0	2.19
1895-4B	1.00	10.0	16.0	4.0	2.19
1895-11	1.00	8.0	16.0	8.0	2.19
1895-11B	1.00	10.0	16.0	8.0	2.19

NOTES:

- DIMENSIONS ARE IN INCHES
- HANDLE IS CENTERED ON PLATES
- FOR USE ON 1.75 THICK DOOR
- FOR CUSTOM SIZES, SEE ORDER FORM 22364

TEMPLATE# 18730

SHEET

1 OF 1

REVISION# 1

APPROVED ON: 4/5/2023

This template is provided for use only on the job for which it was requested. Trimco reserves the right to make design changes without notice. Trimco will not be responsible for errors or damage caused by the use of out-of-date templates.

TRIANGLE BRASS MANUFACTURING
1351 ROCKY POINT DRIVE
OCEANSIDE, CA 92056
WWW.TRIMCOHARDWARE.COM