

TEMPLATE NO.

19802
SHT 1 OF 1



Trimco
SINCE 1949

3528 Emery Street
PO BOX 23277
Los Angeles, CA 90023-0277
(323)262-4191 www.trimcobbw.com
email:info@trimcobbw.com

PRODUCT

LEAD LINER FOR 1562 TUBULAR
LATCH BOLT

BACKSET DEPTH	DIM "A"
2-3/4"	4"
5"	6-1/4"

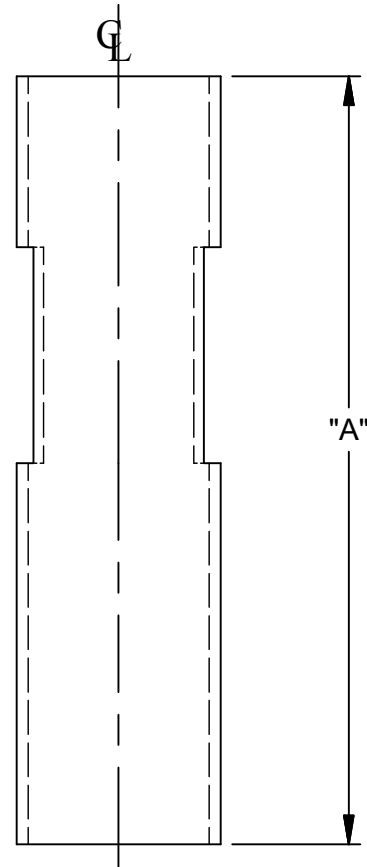
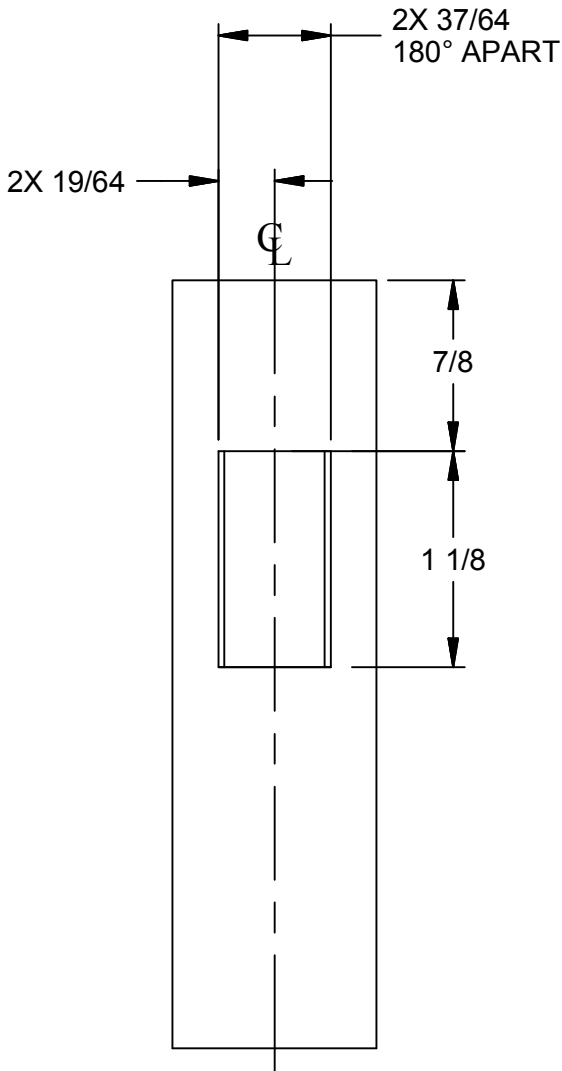
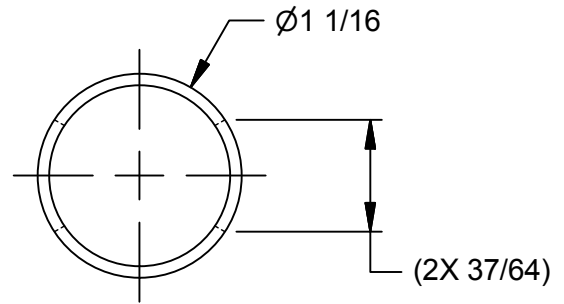

REVISION RECORD:
NEW RELEASE, 09/01/15

PART NUMBER: 1592LLT

NOTE: This template is provided for use only on the job for which is was requested. Trimco reserves the right to make design changes without notice. Trimco will not be responsible for errors or damage caused by the use of out-of-date templates.

DATE

09/01/15