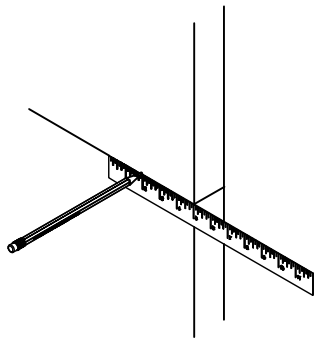
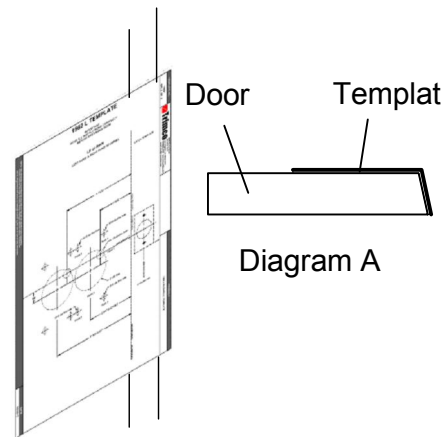
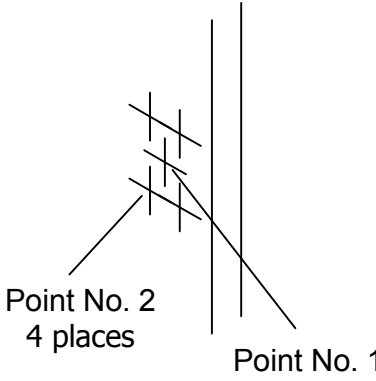
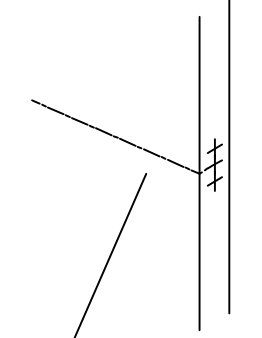
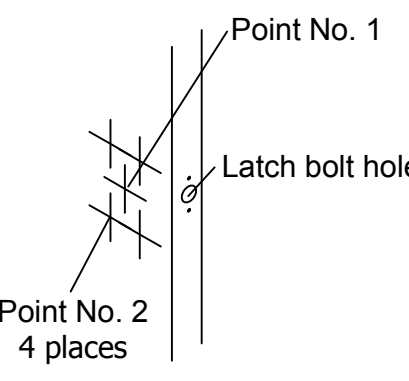
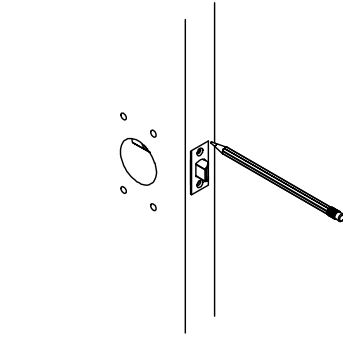
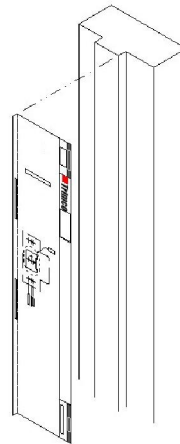
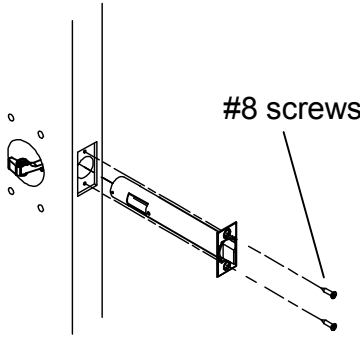
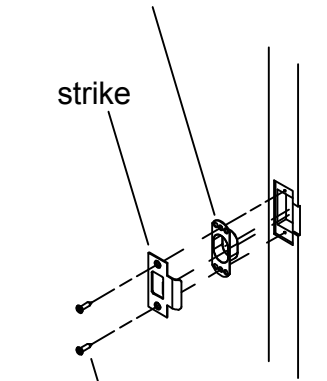
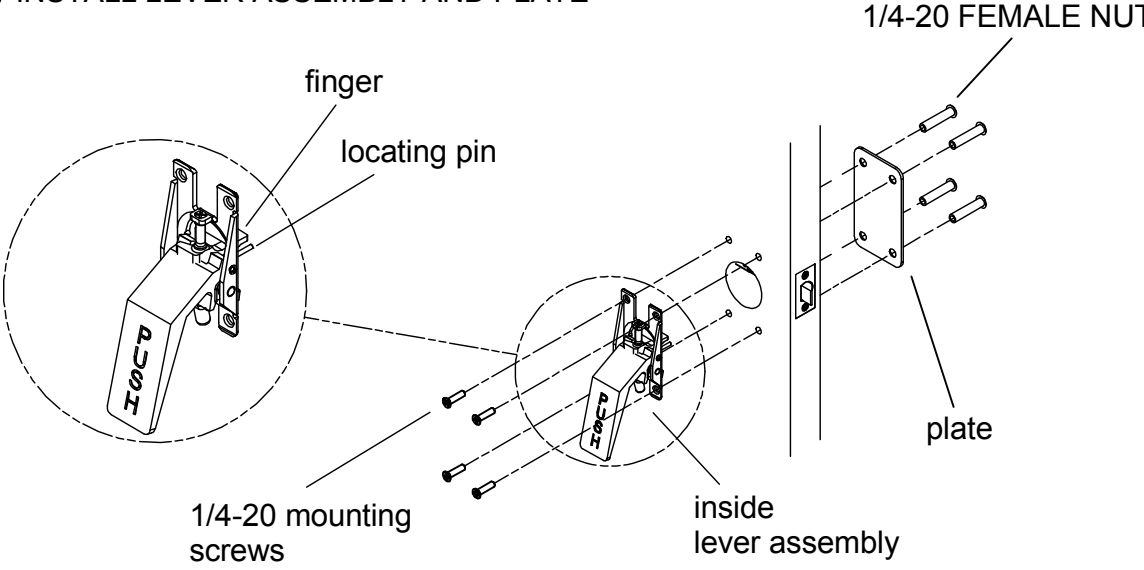
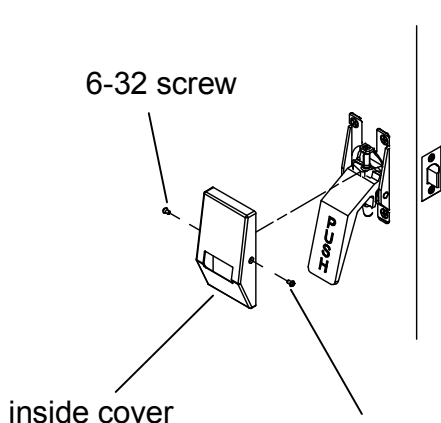

WOOD DOOR AND WOOD FRAME PREPARATION/TEMPLATE INSTRUCTIONS (METAL DOORS/METAL FRAMES SHOULD BE PRE-PREPARED)

<p><b>1 MARK DOOR HEIGHT</b></p>  <p>Draw a horizontal line on both sides of the door to indicate desired height of lever, (45" above floor suggested unless otherwise directed).</p>	<p><b>2 POSITION TEMPLATE</b></p>  <p>Fold (or cut if desired) enclosed latch template on dotted line. Align the line just marked on the door with the latch centerline which is on the latch/lever assy template. Tape template to door.</p>	<p><b>3 MARK DOOR</b></p>  <p>Mark appropriate drill points on door to correspond with points on latch/lever assy template.</p>	<p><b>4 DRILL EDGE BORES</b></p>  <p>Using mortise tool and a 1" bit, mortise for latch to depth of bore.</p>	<p><b>5 DRILL FACE BORES</b></p>  <p>Using a 2 1/8" dia hole saw drill through at point 1. Using 5/16" dia drill bit drill through at point 2 (4 places). Using 1" dia hole saw drill latchbolt hole to a depth of 4 3/8" for 2 3/4" backset, or 6 5/8" for 5" backset.</p>	<p><b>6 MORTISE AND POSITION FACEPLATE</b></p>  <p>Slide latch into mortise. Check that screw mounting points are centered before tracing the outline of the faceplate. Chisel for faceplate to a depth of 5/32".</p>	<p><b>7 PREPARE FRAME</b></p>  <p>Tape strike template at matching centerline to latch template. Mark hole centers. Position strike over frame and trace outline. Chisel to a depth of 3/32" to accommodate strike plate.</p>
------------------------------------------------------------------------------------------------------------------------------------------------------------------------------------------------------------------------------------------------------------------------	--------------------------------------------------------------------------------------------------------------------------------------------------------------------------------------------------------------------------------------------------------------------------------------------------------------------------------	-------------------------------------------------------------------------------------------------------------------------------------------------------------------------------------------------------------------	--------------------------------------------------------------------------------------------------------------------------------------------------------------------------------------------------	----------------------------------------------------------------------------------------------------------------------------------------------------------------------------------------------------------------------------------------------------------------------------------------------------------------------------------------------------------------	----------------------------------------------------------------------------------------------------------------------------------------------------------------------------------------------------------------------------------------------------------------------------------------------------------	------------------------------------------------------------------------------------------------------------------------------------------------------------------------------------------------------------------------------------------------------------------------------------------------------------------

INSTALLATION INSTRUCTIONS

<p><b>1 INSTALL LATCH</b></p>  <p>Place latch bolt unit in door, Making sure bolt bevel faces direction of door closing. Attach front with 2 (two) #8 screws.</p>	<p><b>2 INSTALL STRIKE</b></p>  <p>(3651 "B" strike shown) Install strike and strike box (if customer supplied) using two (2) #8 screws.</p>	<p><b>3 INSTALL LEVER ASSEMBLY AND PLATE</b></p>  <p>Install lever assembly by aligning the mounting holes of the inside lever assembly with the corresponding holes in the door, by inserting the finger into the latch cutout, and inserting the locating pin in the corresponding hole in the latch. Verify handing for each assembly before mounting. Align lever assembly and plate and fasten with four (4) 1/4-20 mounting screws, and four (4) 1/4-20 female nuts.</p> <p>LEFT HAND REVERSE SHOWN</p>	<p><b>4 INSTALL COVER</b></p>  <p>Install cover and fasten with 6-32 screws.</p>
------------------------------------------------------------------------------------------------------------------------------------------------------------------------------------------------------------------------------------------------------	-------------------------------------------------------------------------------------------------------------------------------------------------------------------------------------------------------------------------------------	----------------------------------------------------------------------------------------------------------------------------------------------------------------------------------------------------------------------------------------------------------------------------------------------------------------------------------------------------------------------------------------------------------------------------------------------------------------------------------------------------------------------------------------------------------------------------------------------------	-----------------------------------------------------------------------------------------------------------------------------------------------------------------------