

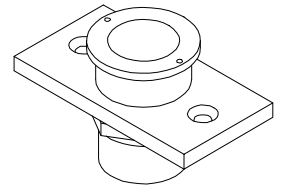

Trimco
SINCE 1949

PRODUCT:

3911 ADJUSTABLE DUST PROOF STRIKE TEMPLATE

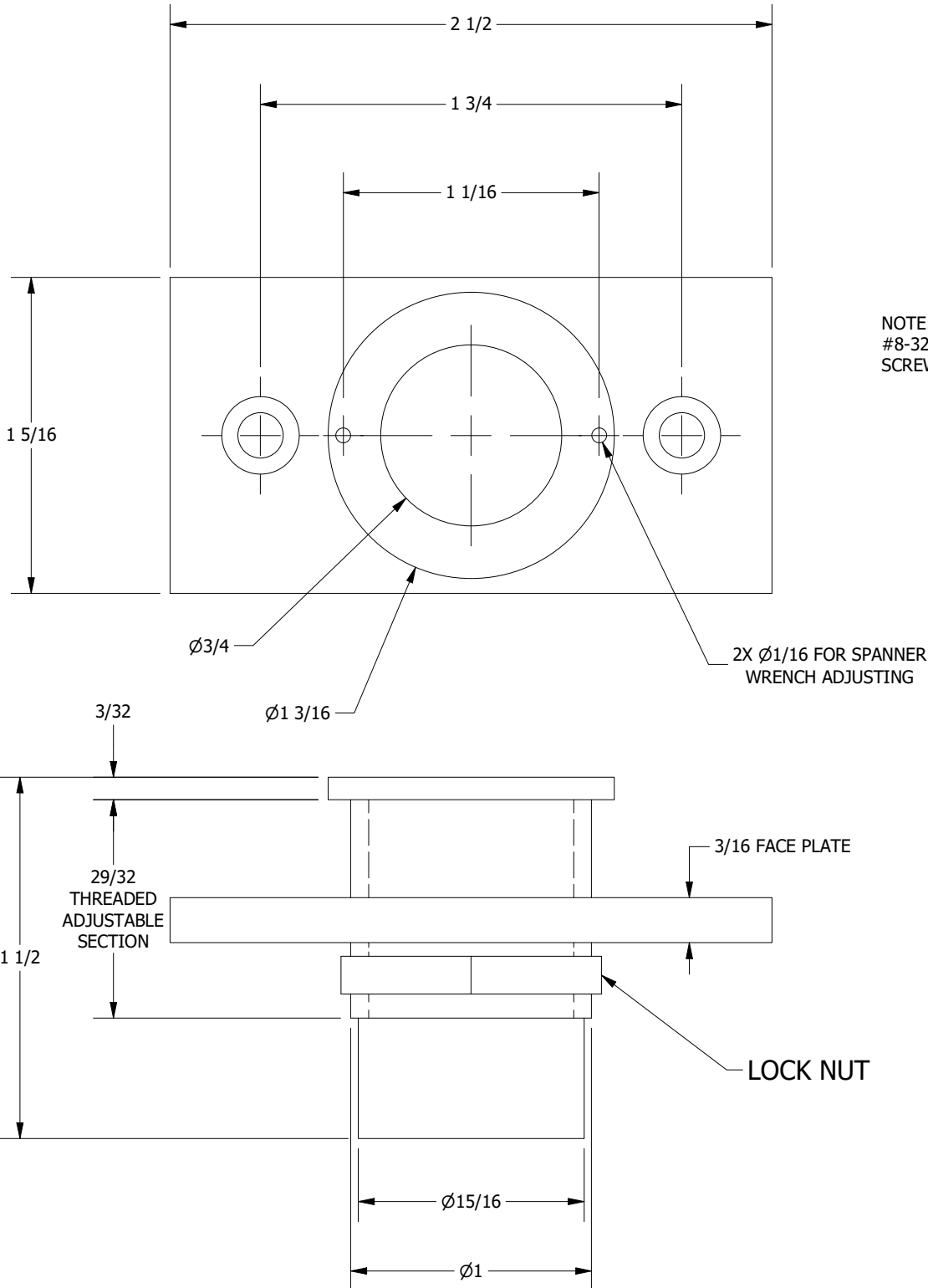

NOTE: PRODUCT SUPPLIED WITH #8-32 OVAL HEAD MACHINE SCREWS AND EXPANSION SHIELDS.

<p>TEMPLATE# 21707</p>	<p>SHEET</p>	<p>1 OF 1</p>	<p>TRIANGLE BRASS MANUFACTURING 1351 ROCKY POINT DRIVE OCEANSIDE, CA 92056 WWW.TRIMCOHARDWARE.COM</p>
<p>REVISION# 01</p>	<p>This template is provided for use only on the job for which it was requested. Trimco reserves the right to make design changes without notice. Trimco will not be responsible for errors or damage caused by the use of out-of-date templates.</p>		
<p>APPROVED ON: 9/8/2020</p>			