

1. RECOMEMDED DOOR CUT-OUT

3-7/8 X 4-3/8

2. DIMENSIONAL TOLERANCES +- .030

REVISIONS			
LTR	DESCRIPTION	DATE	CHECKED
-	NEW DWG	9-11-91	INS
A	REVISED	TA. 11-14-94	<i>[Signature]</i>

REVISED 4-24-13MF

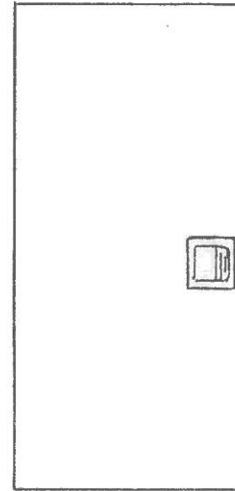
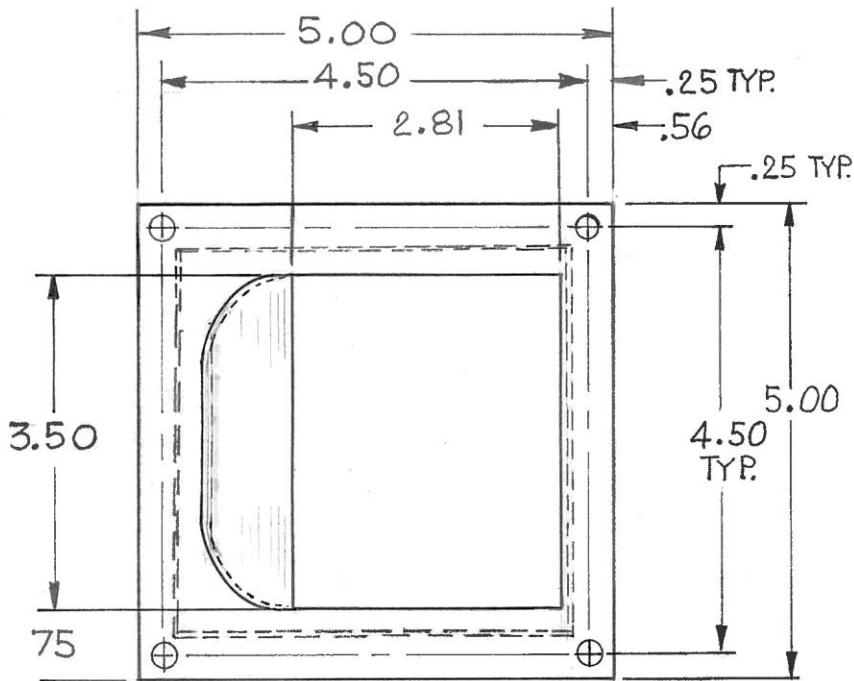

RECOMMENDED ORIENTATION
UNLESS SPECIFIED OTHERWISE

SUPPLIED WITH: 4 - #8 - 32 x 1-3/4 PHILLIPS

HEAD, OVAL HEAD MACHINE SCREW, 4 #8

FINISH WASHERS & 4 #8 - 32 SEX-NUTS FOR

1.75 DOOR THICKNESS

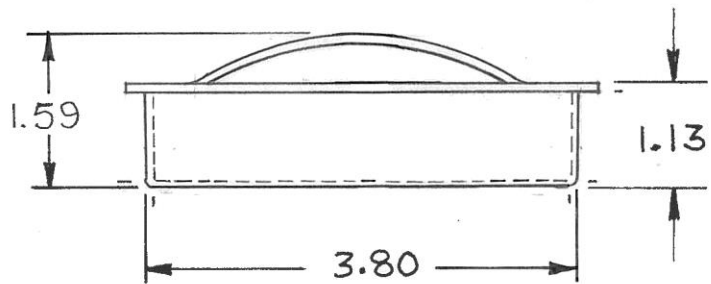
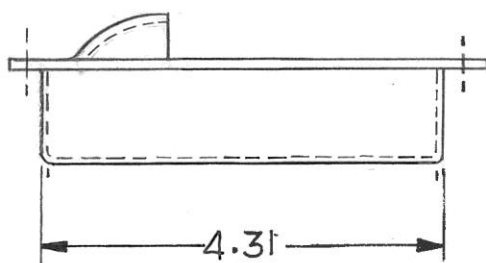

Book No. ___ Date Requested: ___
This template is provided for use only on the job for which it was requested.
Trimco/BBW reserves the right to make design changes without notice.



SCALE	HALF SCALE
USED ON:	1111-B
DRAWN BY	LAR 1-22-91

TITLE	FLUSH PULL
PART NO	1111-B
DWG. NO.	11322